

Axial piston fixed motor A4FM Series 10 and 30

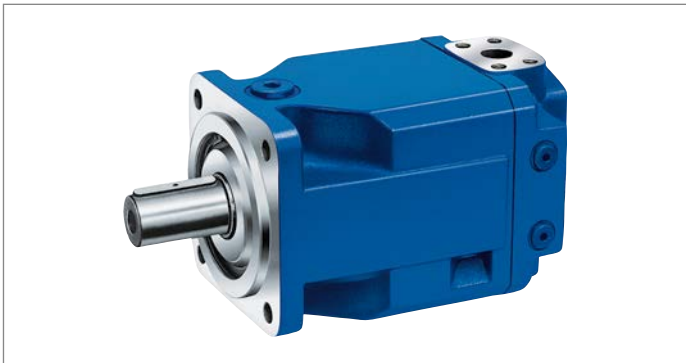

- ▶ High pressure motor for confined installation spaces
- ▶ Sizes 71 to 1000
- ▶ Nominal pressure 350 bar
- ▶ Maximum pressure 400 bar
- ▶ Open and closed circuit

Features

- ▶ Particularly well suited for applications, where a compact installation size is required
- ▶ High tolerance to torsional vibrations
- ▶ Long service life at high pressures
- ▶ Very high total efficiency
- ▶ Low noise
- ▶ Swashplate design

Contents

Type code	2
Hydraulic fluid	3
Shaft seal	4
Flow direction	4
Working pressure range	5
Technical data	6
Dimensions, size 71	10
Dimensions, size 125	12
Dimensions, size 250	14
Dimensions, size 500	16
Dimensions, size 1000	18
Installation instructions	20
Project planning notes	22
Safety instructions	23

Type code

01	02	03	04	05	06	07	08	09	10	
	A4F	M		/		W	-			
Hydraulic fluid						71	125	250	500	1000
01	Mineral oil, HFD hydraulic fluid (no code)					•	•	•	•	•
	HFA, HFB, HFC hydraulic fluid					•	•	•	•	- E
Axial piston unit										
02	Swashplate design, fixed displacement									A4F
Operating mode										
03	Motor, open and closed circuit									M
Size (NG)¹⁾										
04	Geometric displacement, see technical data on page 6					71	125	250	500	1000
Series										
05	Series 1, index 0					•	-	-	-	- 10
	Series 3, index 0					-	•	•	•	• 30
Direction of rotation										
06	Viewed on drive shaft					variable				W
Sealing material						71	125	250	500	1000
07	NBR (nitrile rubber), shaft seal made of FKM (fluoroelastomer)					•	•	•	•	• P
	FKM (fluoroelastomer)					•	•	•	•	• V
Drive shaft						71	125	250	500	1000
08	Splined shaft DIN 5480					•	•	•	•	• Z
	Parallel keyed shaft DIN 6885					•	•	•	•	• P
Mounting flange						71	125	250	500	1000
09	ISO 3019-2; 4-hole					•	•	•	-	- B
	ISO 3019-2; 8-hole					-	-	-	•	• H
Working port						71	125	250	500	1000
10	SAE working port A and B at rear, Metric fastening thread according to DIN 13					•	•	•	-	- 01
	SAE working port A and B , laterally opposite on top and bottom, Metric fastening thread according to DIN 13					•	•	•	-	- 02
	SAE working port A and B laterally, same side, Metric fastening thread according to DIN 13					-	-	-	•	• 10

• = Available ○ = On request - = Not available

Notice

- ▶ Note the project planning notes on page 22.
- ▶ In addition to the type code, please specify the relevant technical data when placing your order.

¹⁾ Additional sizes available on request

Hydraulic fluid

The axial piston unit A4FM is designed for operation with HLP mineral oil according to DIN 51524.

Application instructions and requirements for hydraulic fluid selection, behavior during operation as well as disposal and environmental protection should be taken from the following data sheets before the start of project planning:

- ▶ 90220: Hydraulic fluids based on mineral oils and related hydrocarbons
- ▶ 90221: Environmentally acceptable hydraulic fluids
- ▶ 90222: Fire-resistant, water-free hydraulic fluids (HFDR/HFDU)
- ▶ 90223: Fire-resistant, water-containing hydraulic fluids (HFC/HFB/HFAE/HFAS)

Selection of hydraulic fluid

Bosch Rexroth evaluates hydraulic fluids on the basis of the Fluid Rating according to the technical data sheet 90235.

Hydraulic fluids with positive evaluation in the Fluid Rating are provided in the following technical data sheet:

- ▶ 90245: Bosch Rexroth Fluid Rating List for Rexroth hydraulic components (pumps and motors)

The hydraulic fluid should be selected so that the operating viscosity in the operating temperature range is within the optimum range (ν_{opt} ; see selection diagram).

Viscosity and temperature of hydraulic fluids

	Viscosity	Shaft seal	Temperature ²⁾	Comment
Cold start	$\nu_{max} \leq 1600 \text{ mm}^2/\text{s}$	NBR	$\vartheta_{St} \geq -40^\circ\text{C}$	$-t \leq 3 \text{ min}$, without load ($p \leq 50 \text{ bar}$), $n \leq 1000 \text{ rpm}$ Permissible temperature difference between axial piston unit and hydraulic fluid in the system maximum 25 K
		FKM	$\vartheta_{St} \geq -25^\circ\text{C}$	
Warm-up phase	$\nu = 1600 \dots 400 \text{ mm}^2/\text{s}$			$t \leq 15 \text{ min}$, $p \leq 0.7 \times p_{nom}$ and $n \leq 0.5 \times n_{nom}$
Continuous operation	$\nu = 400 \dots 10 \text{ mm}^2/\text{s}^1)$	NBR	$\vartheta \leq +85^\circ\text{C}$	Measured at port T
		FKM	$\vartheta \leq +110^\circ\text{C}$	
	$\nu_{opt} = 36 \dots 16 \text{ mm}^2/\text{s}$			Optimal operating viscosity and efficiency range
Short-term operation	$\nu_{min} = 10 \dots 7 \text{ mm}^2/\text{s}$	NBR	$\vartheta \leq +85^\circ\text{C}$	$t \leq 3 \text{ min}$, $p \leq 0.3 \times p_{nom}$, measured at port T
		FKM	$\vartheta \leq +110^\circ\text{C}$	

▼ Selection diagram

Maximum permissible viscosity on cold start

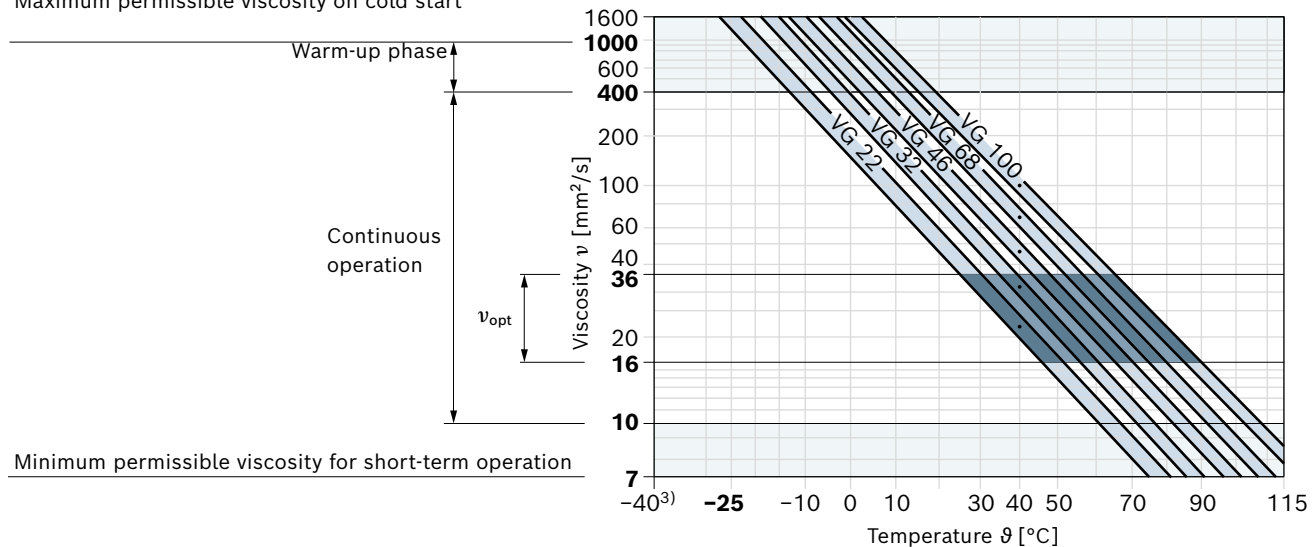

1) This corresponds, for example on the VG 46, to a temperature range of +4°C to +85°C (see selection diagram)

2) If the temperature at extreme operating parameters cannot be adhered to, please contact us.

Filtration of the hydraulic fluid

Finer filtration improves the cleanliness level of the hydraulic fluid, which increases the service life of the axial piston unit.

A cleanliness level of at least 20/18/15 is to be maintained according to ISO 4406.

At a hydraulic fluid viscosity of less than 10 mm²/s (e.g. due to high temperatures during short-term operation) at the drain port, a cleanliness level of at least 19/17/14 according to ISO 4406 is required.

For example, the viscosity corresponds to 10 mm²/s at:

- ▶ HLP 32 to a temperature of 73°C
- ▶ HLP 46 to a temperature of 85°C

Shaft seal

Permissible pressure load

The service life of the shaft seal is influenced by the rotational speed of the axial piston unit and the leakage pressure in the housing (case pressure). Momentary ($t < 0.1$ s) pressure peaks of up to 6 bar are allowed. The service life of the shaft seal decreases with increasing frequency of pressure peaks and increasing mean differential pressure.

The pressure in the housing must be equal to or greater than the ambient pressure.

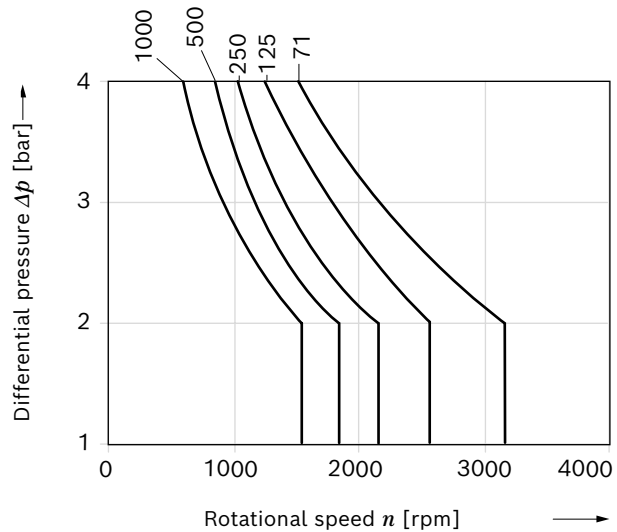

The FKM shaft seal may be used for leakage temperatures from -25°C to +115°C.

Flow direction

Direction of rotation viewed on drive shaft	
right	left
A to B	B to A

▼ Circuit diagram

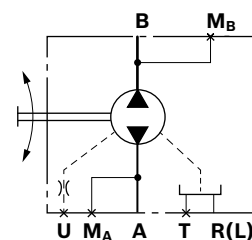

Ports

- A, B** Working port
- T** Drain port
- R(L)** Filling / Air bleeding
- MA, MB** Measuring port
Operating pressure
- U** Flushing port

Bearing flushing (sizes 71 to 1000)

Please refer to the data sheet 92100 (A4VSG) for operating conditions, flushing flows and notices on bearing flushing.

Working pressure range

Pressure at working port A or B		Definition
Nominal pressure p_{nom}	350 bar	The nominal pressure corresponds to the maximum design pressure.
Maximum pressure p_{max}	400 bar	The maximum pressure corresponds to the maximum working pressure within a single operating period. The sum of single operating periods must not exceed the total operating period.
Single operating period	1 s	
Total operating period	300 h	
Minimum pressure (high-pressure side)		Minimum pressure on the high-pressure side (A or B) required to prevent damage to the axial piston unit.
Rate of pressure change $R_{A\ max}$	16000 bar/s	Maximum permissible pressure build-up and reduction speed during a pressure change across the entire pressure range.
Pressure at port A or B (low-pressure side)		
Minimum pressure p_{min}	0.8 bar abs.	Minimum pressure on the low-pressure side that is required in order to prevent damage to the axial piston unit. The minimum pressure is dependent on the rotational speed of the axial piston unit.
Summation pressure		
	450 bar	The sum of the pressures on ports A and B must not rise above 450 bar.
Leakage pressure at port T		
Maximum pressure $p_{L\ max}$	4 bar	Maximum 1.2 bar higher than inlet pressure at port A, but not higher than $p_{L\ max}$. A drain line to the reservoir is required.
Pressure peaks $p_{L\ peak}$	6 bar	$t < 0.1\ s$

▼ Rate of pressure change $R_{A\ max}$

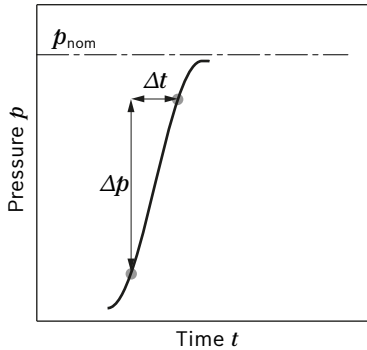

▼ Pressure definition

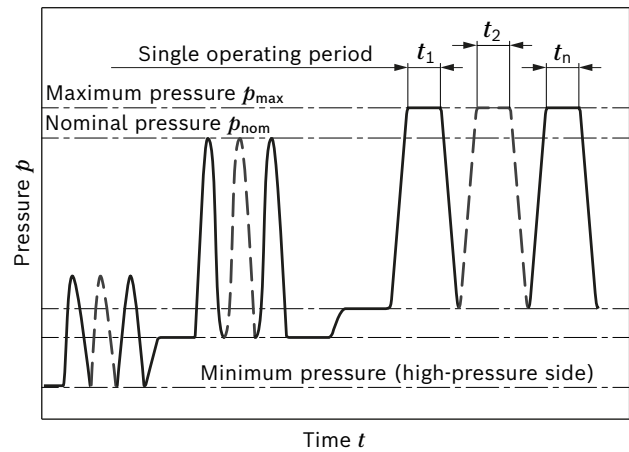

$$\text{Total operating period} = t_1 + t_2 + \dots + t_n$$

Notice

Working pressure range applies when using hydraulic fluids based on mineral oils. Please contact us for values for other hydraulic fluids.

Technical data

Size	NG		71	125	250	500	1000	
Geometric displacement, per revolution	V_g	cm ³	71	125	250	500	1000	
Maximum rotational speed ¹⁾	n_{nom}	rpm	3200	2600	2200	1800	1600	
Inlet flow	at V_g and n_{nom}	q_v	l/min	227	325	550	900	1600
Power	at V_g , n_{nom} and $\Delta p = 350$ bar	P	kW	91	131	277	525	933
Torque	at V_g and $\Delta p = 350$ bar	M	Nm	396	696	1393	2783	5565
Torque constant		M_K	Nm/bar	1.13	1.99	3.97	7.95	15.9
Rotary stiffness	Shaft end P	c	kNm/rad	146	260	527	1145	2730
Drive shaft	Shaft end Z	c	kNm/rad	146	263	543	1136	2845
Moment of inertia of the rotary group		J_{TW}	kgm ²	0.0121	0.0300	0.0959	0.3325	1.20
Actual starting torque at $n = 0$ rpm and $\Delta p = 350$ bar (approx.)			Nm	320	564	1127	2254	4507
Maximum angular acceleration		a	rad/s ²	20000	13000	8000	2800	1450
Case volume		V	l	2.0	3.0	7.0	11.0	27
Weight (approx.)		m	kg	34	61	120	220	423

Notice

- ▶ Theoretical values, without efficiency and tolerances; values rounded
- ▶ Operation above the maximum values or below the minimum values may result in a loss of function, a reduced service life or in the destruction of the axial piston unit. Other permissible limit values, such as speed variation, reduced angular acceleration as a function of the frequency and the permissible angular acceleration at start (lower than the maximum angular acceleration) can be found in data sheet 90261.
- ▶ The values given are maximum values and do not apply to continuous operation

Determination of the operating characteristics

Inlet flow	$q_v = \frac{V_g \times n}{1000 \times \eta_v}$	[l/min]
Output torque	$M = \frac{V_g \times \Delta p \times \eta_{mh}}{20 \times \pi}$ $M = M_K \times \Delta p \times \eta_{mh}$	[Nm]
Output speed	$n = \frac{q_v \times 1000 \times \eta_v}{V_g}$	[rpm]
Power	$P = \frac{2 \pi \times M \times n}{60000} = \frac{T \times n}{9549}$ $P = \frac{q_v \times \Delta p \times \eta_t}{600}$	[kW]

Key		
V_g	=	Displacement per revolution [cm ³]
Δp	=	Differential pressure [bar]
n	=	Rotational speed [rpm]
η_v	=	Volumetric efficiency
η_{mh}	=	Mechanical-hydraulic efficiency
η_t	=	Total efficiency ($\eta_t = \eta_v \times \eta_{mh}$)
M_K	=	Torque constant

1) The values are applicable:
 – at an absolute pressure $p_{abs} = 1$ bar at the low-pressure side (input)
 – for the optimum viscosity range from $\nu_{opt} = 36$ to 16 mm²/s
 – with hydraulic fluid on the basis of mineral oils.

Permissible radial and axial loading of the drive shaft

Size	NG		71	71	125	125	250	250	500	500	1000	1000
Drive shaft Z according to DIN 5480				W40		W50		W60		W80		W100
Drive shaft P according to DIN 6885		mm	Ø40		Ø50		Ø60		Ø80		Ø80	
Maximum radial force at distance a (from shaft collar)	$F_{q \max}$	N	1200	1200	1600	1600	2000	2000	2500	2500	3500	3500
	a	mm	35	22.5	41	27	52.5	35	65	45	82.5	52.5
Maximum axial force	$+ F_{ax \max}$	N	800	800	1000	1000	1800	1800	2000	2000	2200	2200
	$- F_{ax \max}$	N	800	800	1000	1000	1800	1800	2000	2000	2200	2200

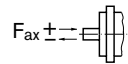
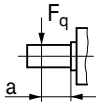
Notice

- ▶ Special requirements apply in the case of belt drive and cardan shaft. Please contact us.
- ▶ The values given are maximum values and do not apply for continuous operation. All shaft loadings reduce the bearing service life.

Inlet flow and output torque

Operating fluid:

Hydraulic fluid ISO VG 46 DIN 51519; $t = 50^\circ\text{C}$

▼ **Size 71**

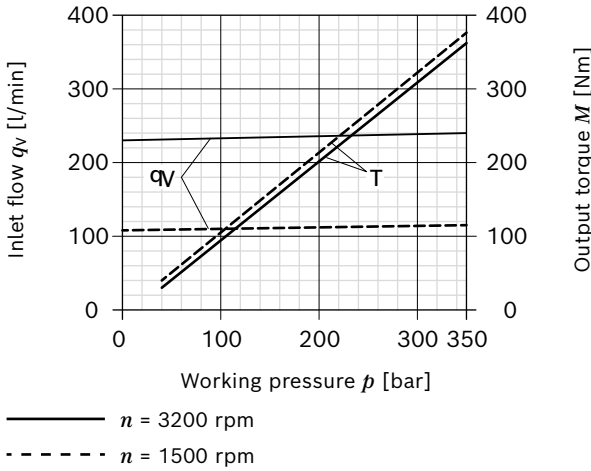

▼ **Size 250**

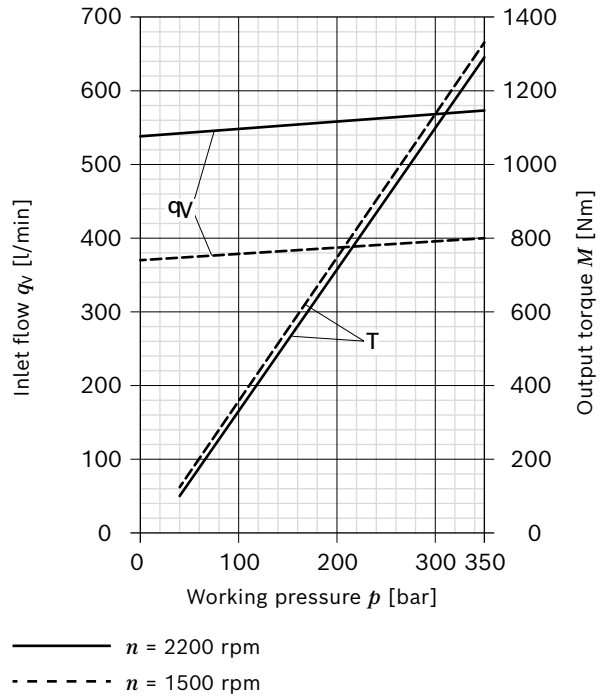

▼ **Size 125**

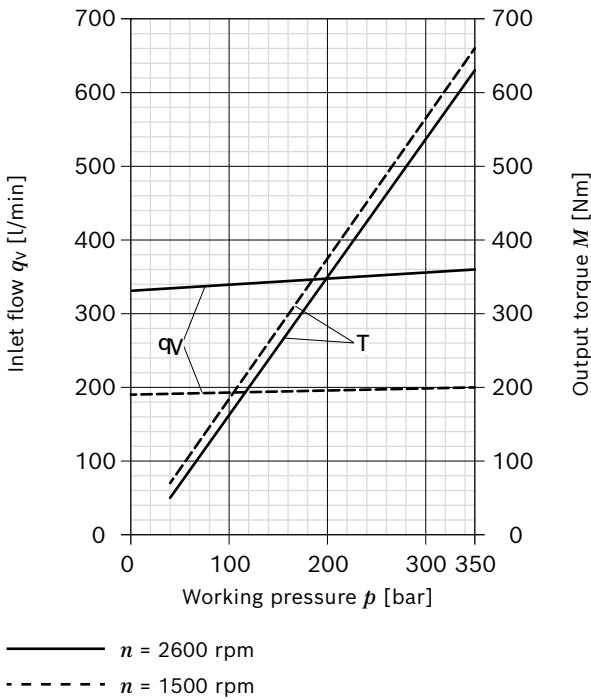

Inlet flow and output torque

Operating fluid:

Hydraulic fluid ISO VG 46 DIN 51519; $t = 50^{\circ}\text{C}$

▼ **Size 500**

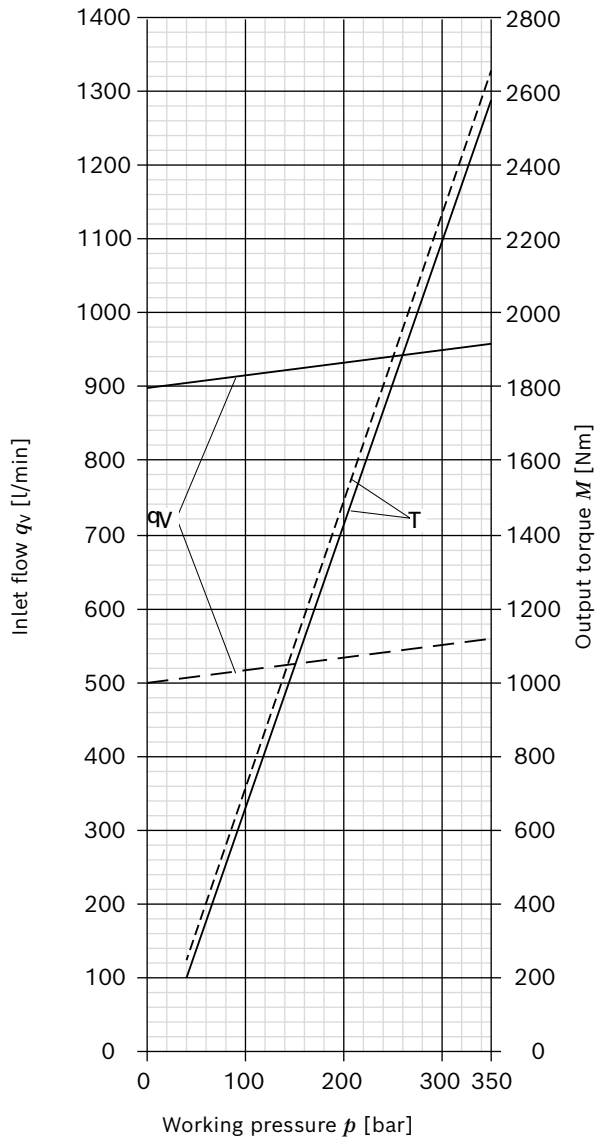

— $n = 1800$ rpm
 - - - $n = 1000$ rpm

▼ **Size 1000**

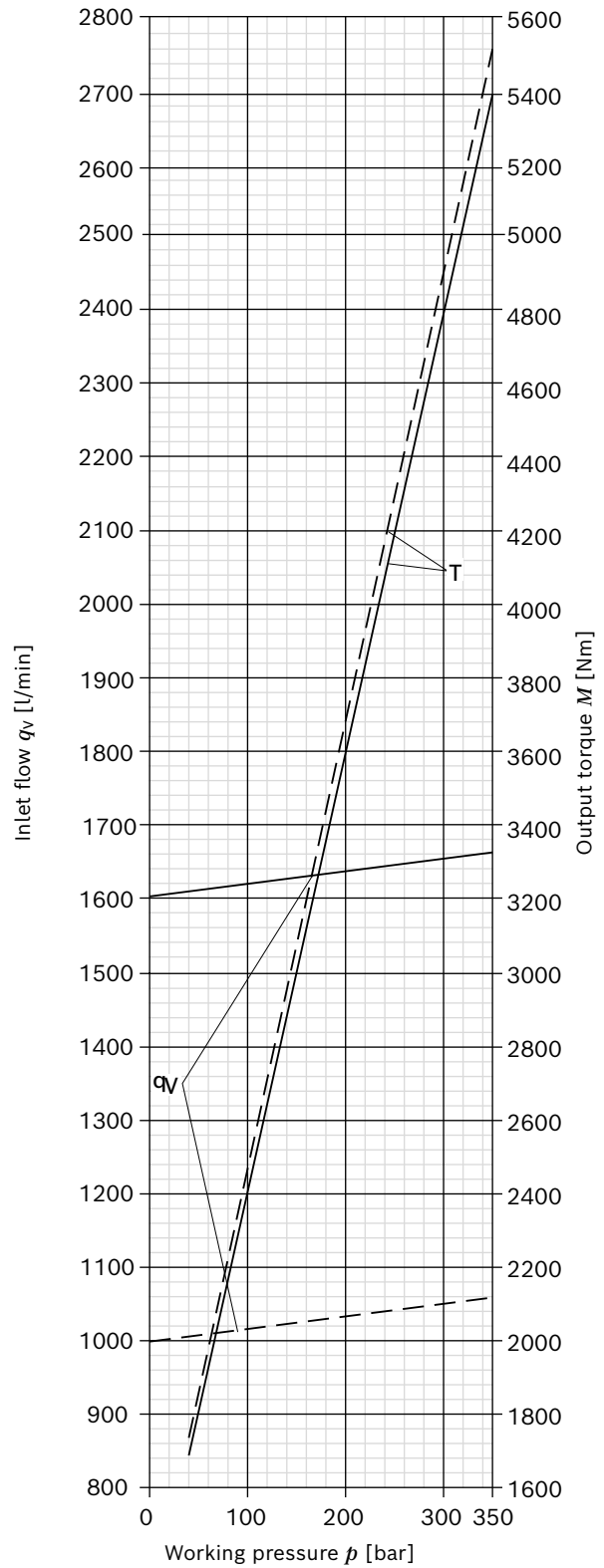

— $n = 1600$ rpm
 - - - $n = 1000$ rpm

Dimensions, size 71

Representation with port plate 01 and 02

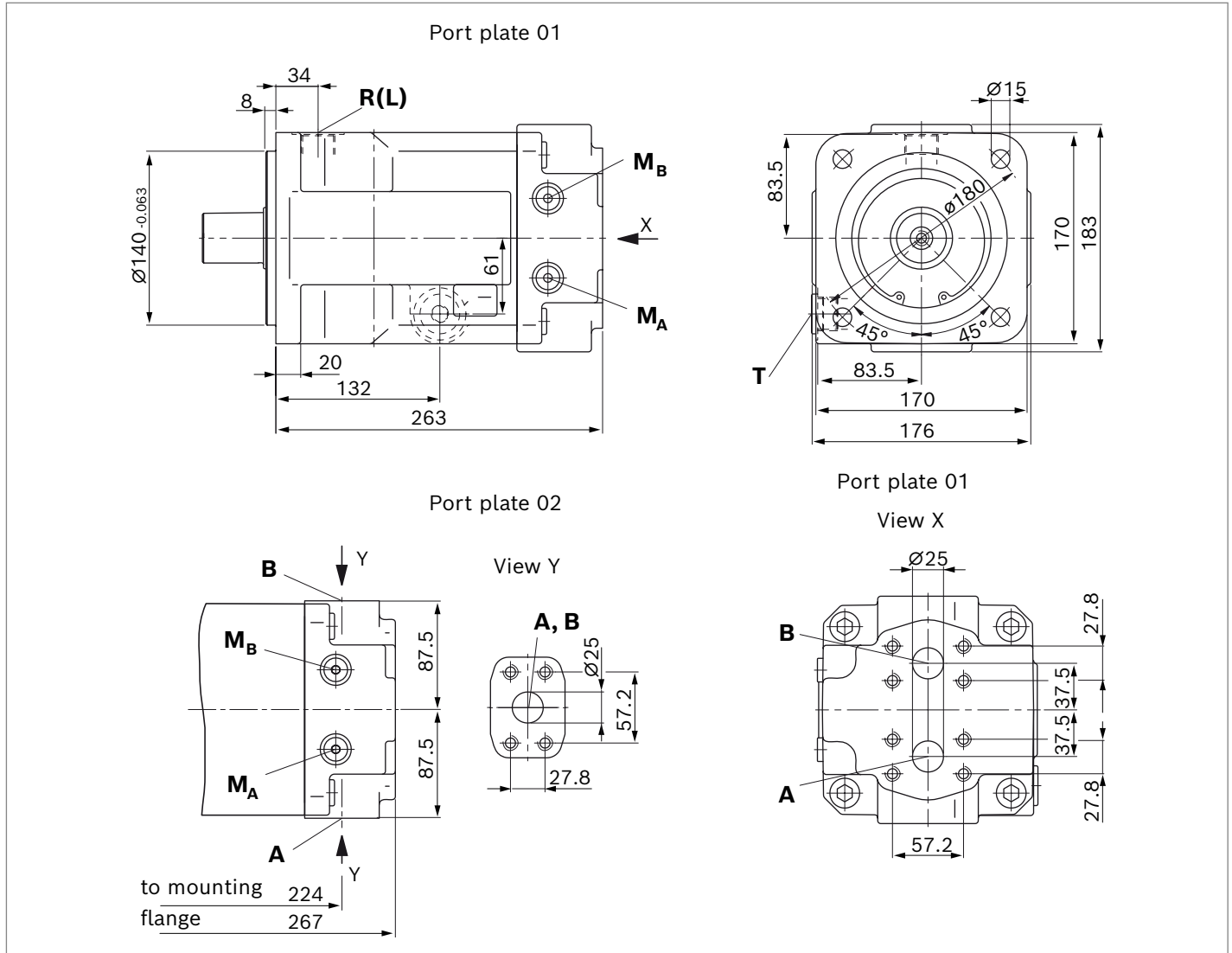

▼ **Splined shaft DIN 5480**

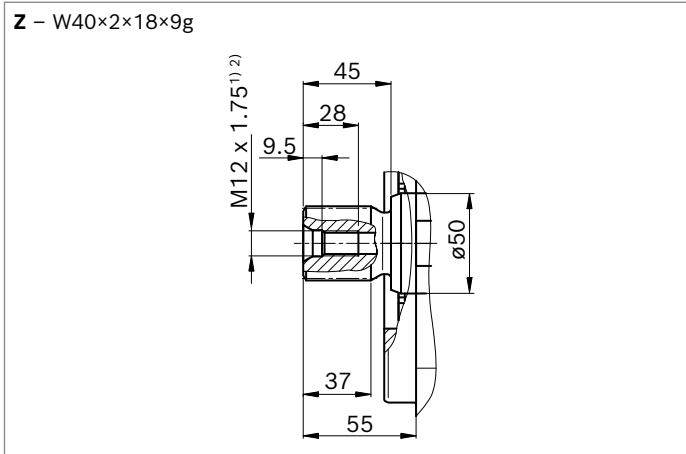

▼ **Parallel keyed shaft DIN 6885**

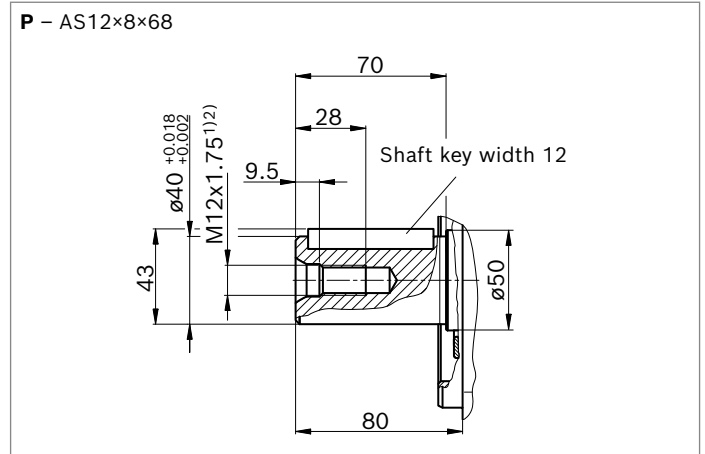

Ports		Standard	Size	$p_{max abs}$ [bar] ³⁾	State
A. B	Working port (high-pressure series) Fastening thread	SAE J518 ⁴⁾ DIN 13	1 in M12 × 1.75; 17 deep	400	O
T	Drain port	DIN 3852 ⁵⁾	M27 × 2; 16 deep	6	X
R (L)	Filling / Air bleeding (drain port)	DIN 3852 ⁵⁾	M27 × 2; 16 deep	6	O
M_B	Measuring pressure B	DIN 3852 ⁵⁾	M14 × 1.5; 12 deep	400	X
M_A	Measuring pressure A	DIN 3852 ⁵⁾	M14 × 1.5; 12 deep	400	X

1) Center bore according to DIN 332.
 2) Thread according to DIN 13.
 3) Depending on the application, momentary pressure peaks can occur. Keep this in mind when selecting measuring devices and fittings.

4) Only dimensions according to SAE J518, metric fastening thread is a deviation from the standard.
 5) The countersink can be deeper than specified in the standard.
 O = Must be connected (plugged on delivery)
 X = Plugged (in normal operation)

Dimensions, size 125

Representation with port plate 01 and 02

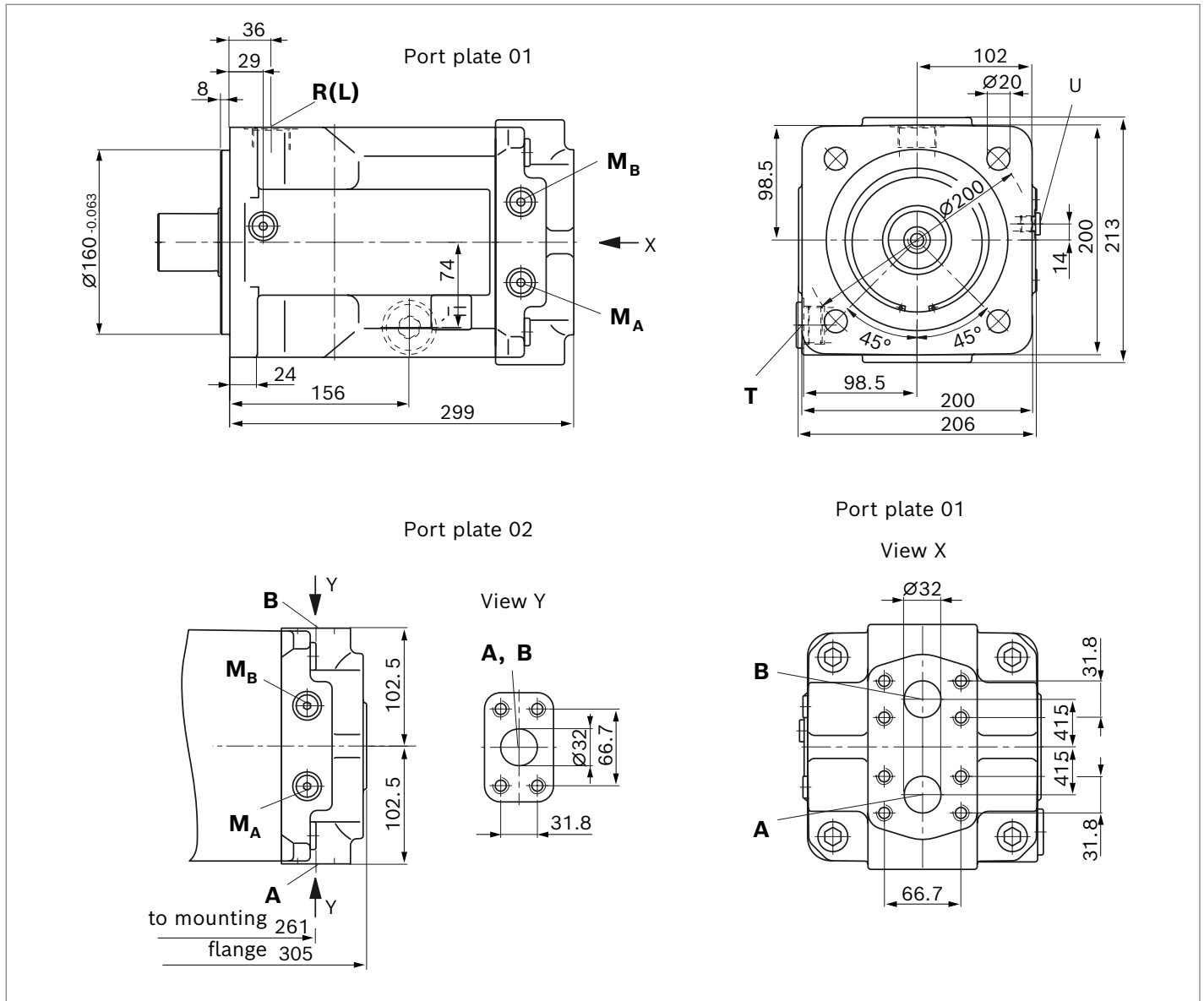

▼ **Splined shaft DIN 5480**

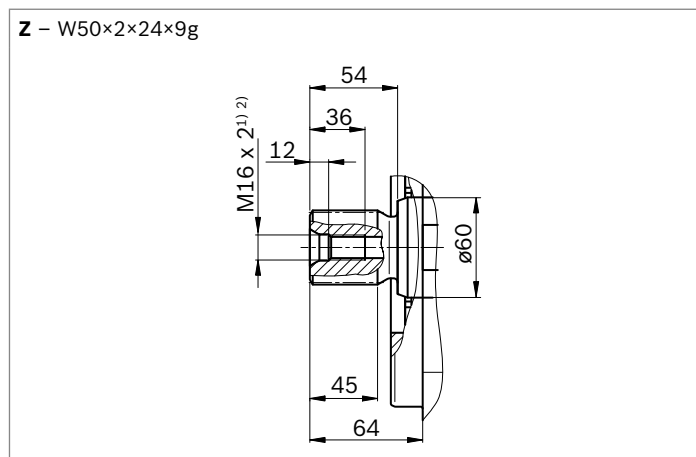

▼ **Parallel keyed shaft DIN 6885**

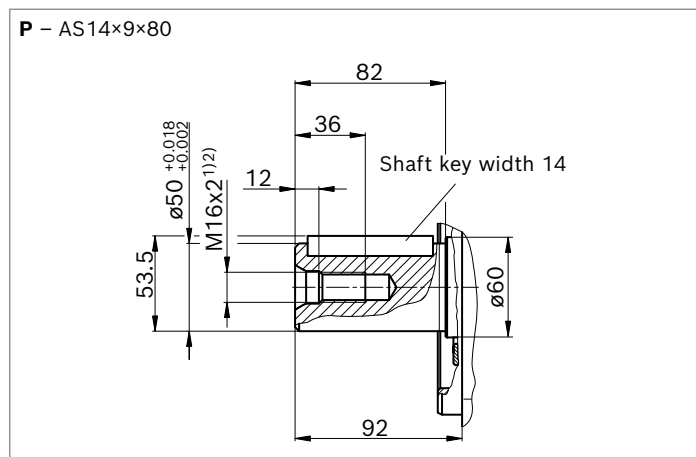

Ports		Standard	Size	$p_{max abs}$ [bar] ³⁾	State
A, B	Working port (high-pressure series) Fastening thread	SAE J518 ⁴⁾ DIN 13	1 1/4 in M14 × 2; 19 deep	400	O
T	Drain port	DIN 3852 ⁵⁾	M33 × 2; 18 deep	6	X
R (L)	Filling / Air bleeding (drain port)	DIN 3852 ⁵⁾	M33 × 2; 18 deep	6	O
M_B	Measuring pressure B	DIN 3852 ⁵⁾	M14 × 1.5; 12 deep	400	X
M_A	Measuring pressure A	DIN 3852 ⁵⁾	M14 × 1.5; 12 deep	400	X
U	Bearing flushing	DIN 3852 ⁵⁾	M14 × 1.5; 12 deep	10	X

1) Center bore according to DIN 332
 2) Thread according to DIN 13
 3) Depending on the application, momentary pressure peaks can occur. Keep this in mind when selecting measuring devices and fittings.

4) Only dimensions according to SAE J518, metric fastening thread is a deviation from the standard.
 5) The countersink can be deeper than specified in the standard.
 O = Must be connected (plugged on delivery)
 X = Plugged (in normal operation)

Dimensions, size 250

Representation with port plate 01 and 02

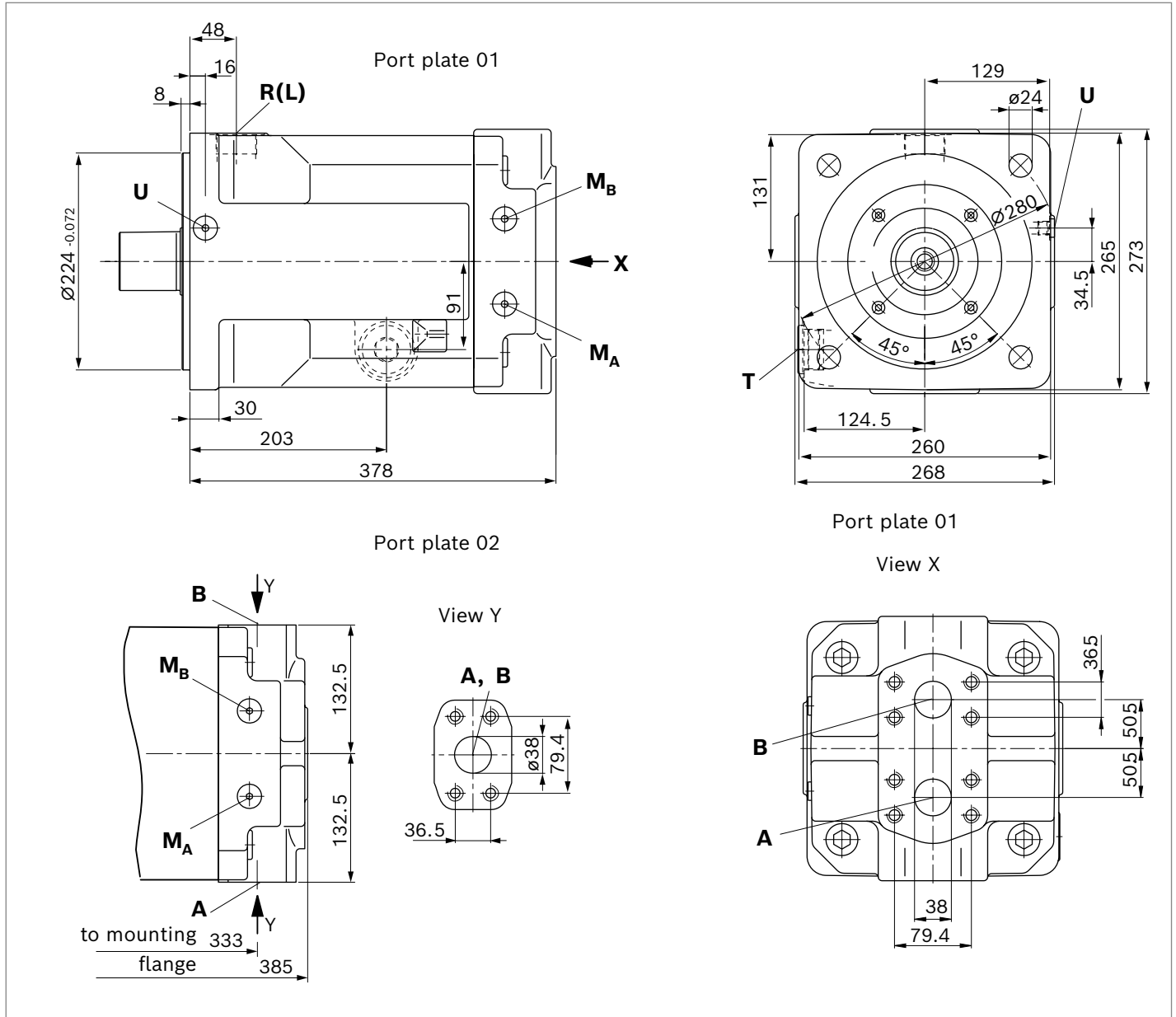

▼ **Splined shaft DIN 5480**

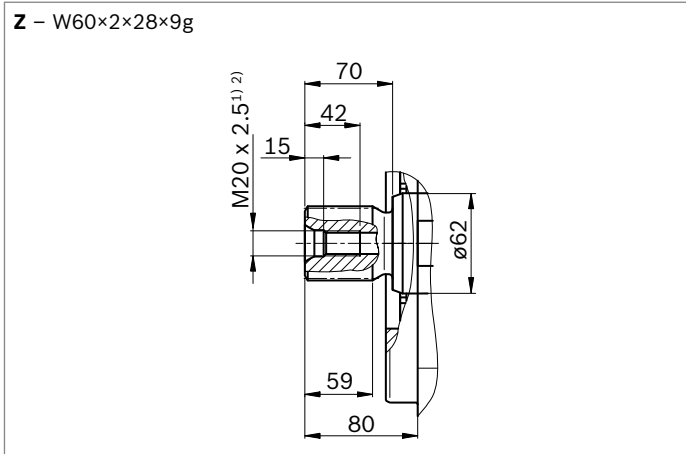

▼ **Parallel keyed shaft DIN 6885**

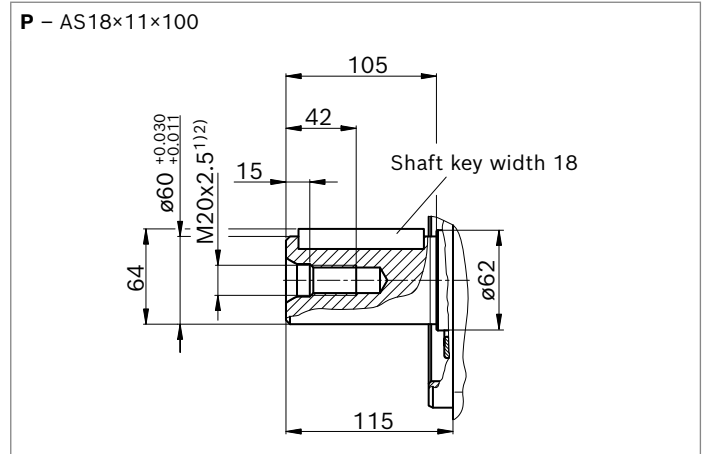

Ports		Standard	Size ²⁾	$p_{max abs}$ [bar] ³⁾	State
A, B	Working port (high-pressure series) Fastening thread	SAE J518 ⁴⁾ DIN 13	1 1/2 in M16 × 2; 24 deep	400	O
T	Drain port	DIN 3852 ⁵⁾	M42 × 2; 20 deep	4	X
R (L)	Filling / Air bleeding (drain port)	DIN 3852 ⁵⁾	M42 × 2; 20 deep	4	O
M_B	Measuring pressure B	DIN 3852 ⁵⁾	M14 × 1.5; 12 deep	400	X
M_A	Measuring pressure A	DIN 3852 ⁵⁾	M14 × 1.5; 12 deep	30	X
U	Bearing flushing	DIN 3852 ⁵⁾	M14 × 1.5; 12 deep	10	X

1) Center bore according to DIN 332 (thread according to DIN 13)
 2) For notices on tightening torques, see the instruction manual.
 3) Depending on the application, momentary pressure peaks can occur. Keep this in mind when selecting measuring devices and fittings.

4) Only dimensions according to SAE J518, metric fastening thread is a deviation from the standard.
 5) The countersink can be deeper than specified in the standard.
 O = Must be connected (plugged on delivery)
 X = Plugged (in normal operation)

▼ Splined shaft DIN 5480

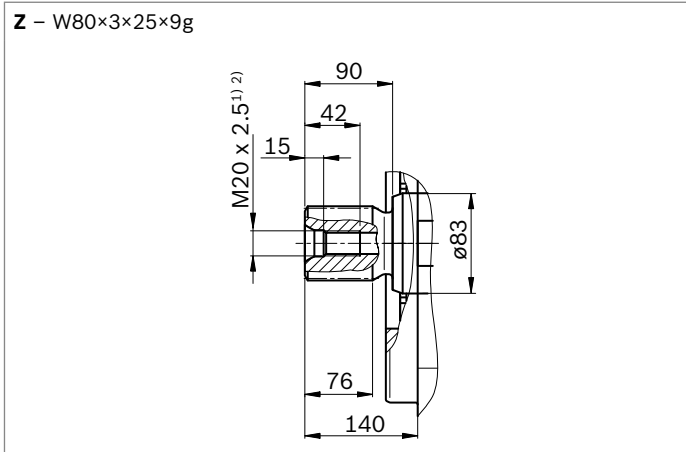

▼ Parallel keyed shaft DIN 6885

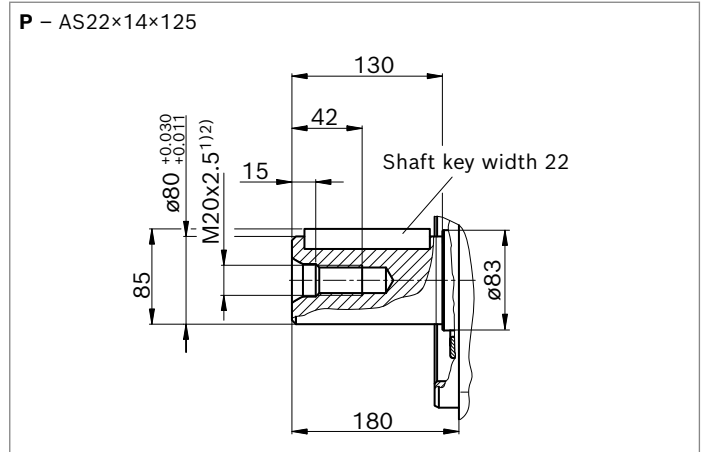

Ports		Standard	Size ²⁾	$p_{\max \text{ abs}}$ [bar] ³⁾	State
A, B	Working port (high-pressure series) Fastening thread	SAE J518 ⁴⁾ DIN 13	2 in M20 × 2.5; 24 deep	400	O
T	Drain port	DIN 3852 ⁵⁾	M48 × 2; 20 deep	4	X
R (L)	Filling / Air bleeding (drain port)	DIN 3852 ⁵⁾	M48 × 2; 20 deep	4	O
M_B	Measuring pressure B	DIN 3852 ⁵⁾	M18 × 1.5; 12 deep	400	X
M_A	Measuring pressure A	DIN 3852 ⁵⁾	M18 × 1.5; 12 deep	30	X
U	Bearing flushing	DIN 3852 ⁵⁾	M18 × 1.5; 12 deep	10	X

1) Center bore according to DIN 332.
 2) Thread according to DIN 13.
 3) Depending on the application, momentary pressure peaks can occur. Keep this in mind when selecting measuring devices and fittings.

4) Only dimensions according to SAE J518, metric fastening thread is a deviation from the standard.
 5) The countersink can be deeper than specified in the standard.
 O = Must be connected (plugged on delivery)
 X = Plugged (in normal operation)

Dimensions, size 1000

Representation with port plate 10

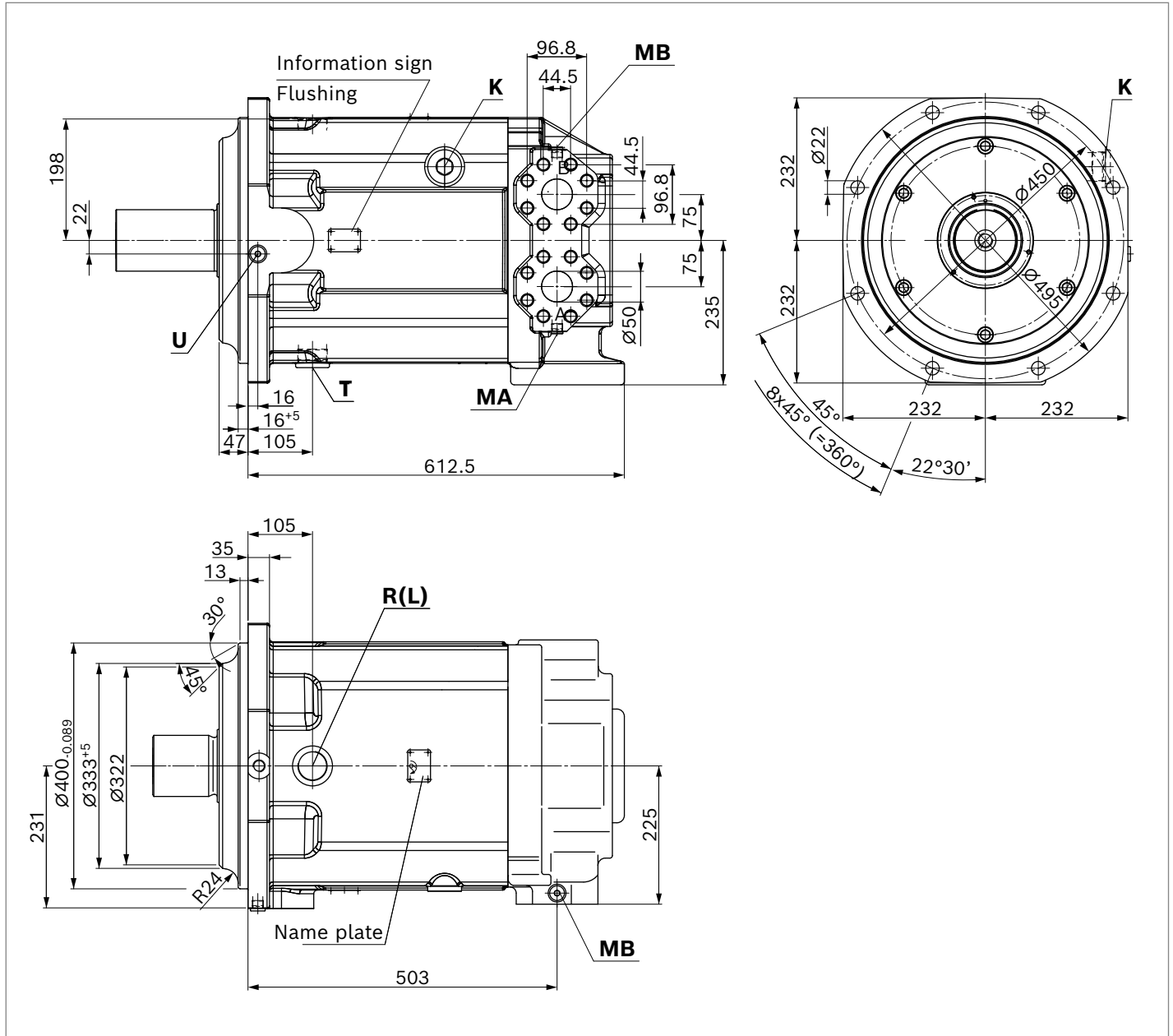

▼ **Splined shaft DIN 5480**

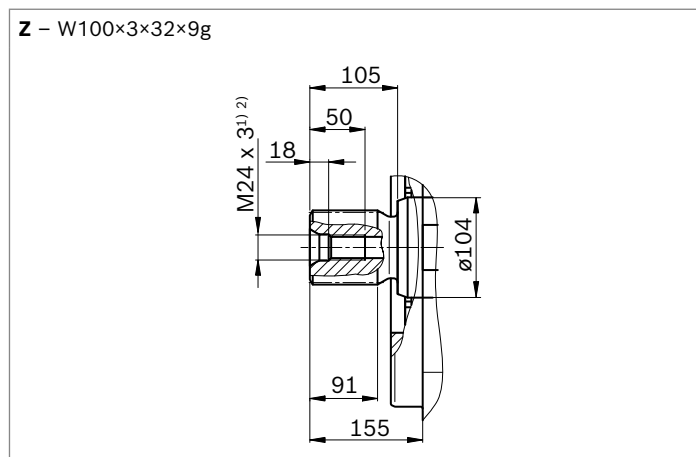

▼ **Parallel keyed shaft DIN 6885**

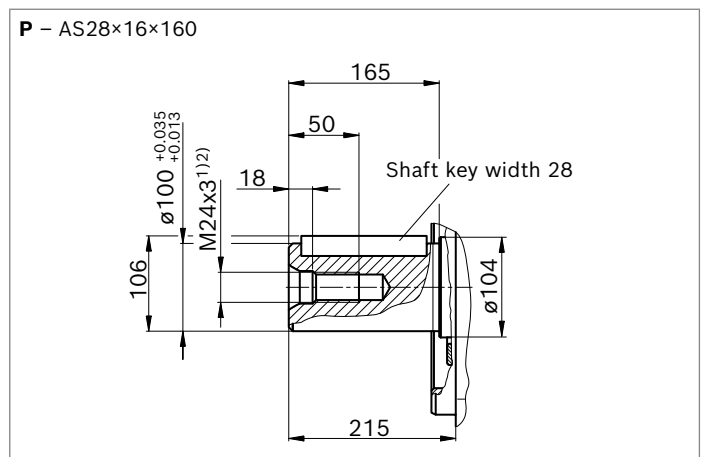

Ports		Standard	Size ²⁾	$p_{max abs}$ [bar] ³⁾	State
A, B	Working port (high-pressure series) Fastening thread	SAE J518 ⁴⁾ DIN 13	2 in M20 × 2.5; 30 deep	400	O
T	Drain port	DIN 3852 ⁵⁾	M48 × 2; 20 deep	4	X
R (L)	Filling / Air bleeding (drain port)	DIN 3852 ⁵⁾	M48 × 2; 20 deep	4	O
M_B	Measuring pressure B	DIN 3852 ⁵⁾	M18 × 1.5; 12 deep	400	X
M_A	Measuring pressure A	DIN 3852 ⁵⁾	M18 × 1.5; 12 deep	30	X
U	Bearing flushing	DIN 3852 ⁵⁾	M18 × 1.5; 12 deep	10	X
K	Flushing	DIN 3852 ⁵⁾	M48 × 2; 20 deep	4	X

1) Center bore according to DIN 332.
 2) Thread according to DIN 13.
 3) Depending on the application, momentary pressure peaks can occur. Keep this in mind when selecting measuring devices and fittings.

4) Only dimensions according to SAE J518, metric fastening thread is a deviation from the standard.
 5) The countersink can be deeper than specified in the standard.
 O = Must be connected (plugged on delivery)
 X = Plugged (in normal operation)

Installation instructions

General

The axial piston unit must be filled with hydraulic fluid and air bled during commissioning and operation. This must also be observed following a longer standstill as the axial piston unit may empty via the hydraulic lines. Particularly in the installation position “drive shaft upwards”, filling and air bleeding must be carried out completely as there is, for example, a danger of dry running.

The leakage in the housing area must be directed to the reservoir via the highest available drain port (**T (R(L))**). If a shared drain line is used for several units, make sure that the respective case pressure in each unit is not exceeded. The shared drain line must be dimensioned to ensure that the maximum permissible case pressure of all connected units is not exceeded in any operating condition, particularly at cold start. If this is not possible, separate drain line must be laid, if necessary. To achieve favorable noise values, decouple all connecting lines using elastic elements and avoid above-reservoir installation.

In all operating conditions, the drain line must flow into the reservoir below the minimum fluid level.

Installation position

See the following examples **1** to **4**.

Further installation positions are available upon request.

Below-reservoir installation (standard)

Below-reservoir installation means that the axial piston unit is installed outside of the reservoir below the minimum fluid level.

Installation position	Air bleed	Filling
1	F (R(L))	F (R(L))
2	F (R(L))	F (R(L)) (U) Bearing flushing

Key, see page 17.

Above-reservoir installation

Above-reservoir installation means that the axial piston unit is installed above the minimum fluid level of the reservoir.

Installation position	Air bleed	Filling
3	F (R (L))	F (R (L))

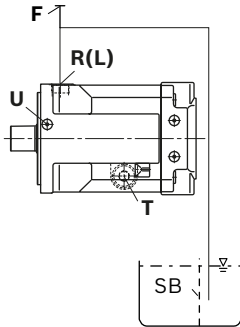

4	F (R(L))	F (R(L)) (U) Bearing flushing
---	----------	----------------------------------

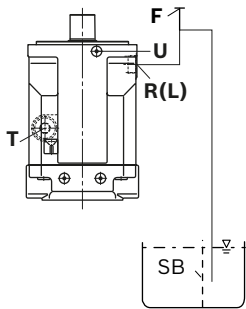

Key	
T	Drain port
R(L)	Filling / Air bleeding
F	Filling / Air bleeding
SB	Baffle (baffle plate)
U	Flushing port for bearing flushing

Notice

Port **F** is part of the external piping and must be provided on the customer side to make filling and air bleeding easier.

Project planning notes

- ▶ The Axial piston fixed motor A4FM is designed to be used in open and closed circuits.
- ▶ Project planning, installation and commissioning of the axial piston units requires the involvement of skilled personnel.
- ▶ Before using the axial piston unit, please read the appropriate instruction manual thoroughly and in full. If necessary, this can be requested from Bosch Rexroth.
- ▶ Before finalizing your design, request a binding installation drawing.
- ▶ The specified data and notices contained herein must be observed.
- ▶ Preservation: Our axial piston units are supplied as standard with preservative protection for a maximum of 12 months. If longer preservative protection is required (maximum 24 months), please specify this in plain text when placing your order. The preservation periods apply under optimal storage conditions, details of which can be found in the data sheet 90312 or the instruction manual.
- ▶ For drives that are operated for a long period with constant rotational speed, the natural frequency of the hydraulic system can be stimulated by the excitation frequency of the pump (rotational speed frequency $\times 9$). This can be prevented with suitably designed hydraulic lines.
- ▶ Please note the details regarding the tightening torques of port threads and other threaded joints in the instruction manual.
- ▶ Working ports:
 - The ports and fastening threads are designed for the specified maximum pressure. The machine or system manufacturer must ensure the connecting elements and lines correspond to the specified application conditions (pressure, flow, hydraulic fluid, temperature) with the necessary safety factors.
 - The service ports and function ports are only designed to accommodate hydraulic lines.

Safety instructions

- ▶ During and shortly after operation, there is a risk of burning on the axial piston unit. Take the appropriate safety measures (e.g. by wearing protective clothing).

Bosch Rexroth AG

An den Kelterwiesen 14
72160 Horb a.N.
Germany
Tel. +49 7451 92-0
info.ma@boschrexroth.de
www.boschrexroth.com

© Bosch Rexroth AG 2020. All rights reserved, also regarding any disposal, exploitation, reproduction, editing, distribution as well as in the event of applications for industrial property rights. The data specified within only serves to describe the product. No statements concerning a certain condition or suitability for a certain application can be derived from our information. The information given does not release the user from the obligation of own judgment and verification. It must be remembered that our products are subject to a natural process of wear and aging.